



REFUSE GRAPPLE RAKES

FOR WHEEL LOADERS, TRACK LOADERS
AND FELLER BUNCHERS

OVERVIEW

Dymax Refuse Grapple Rakes are available for wheel and track loaders and also work with wheeled feller bunchers. This attachment is ideal for large scale land clearing and waste handling applications. Quickly stack, load and sort various materials into tub grinders or trucks or collect for burn piles. Equipped with coupler hooks to fit many popular brands of loaders.

Applications: C&D debris removal; recycling and scrap yards; disaster response and storm cleanup; forestry and land clearing; stump removal; waste management and disposal; mulch and composting.

DX-RK-RFDG OR DX-RK-RFFG

Built to withstand the harsh applications of land clearing and for those seeking high capacity. For machines 26,000-60,000 lbs in operating weight.

1. T1 steel high strength tines with reinforced tine tips
2. Available with dual (RFDG) or full width grapples (RFFG)
3. 115 inches of opening
4. Smooth tines with 10.5 inch spacing on average
5. 48 inch tine length with dozer push plate

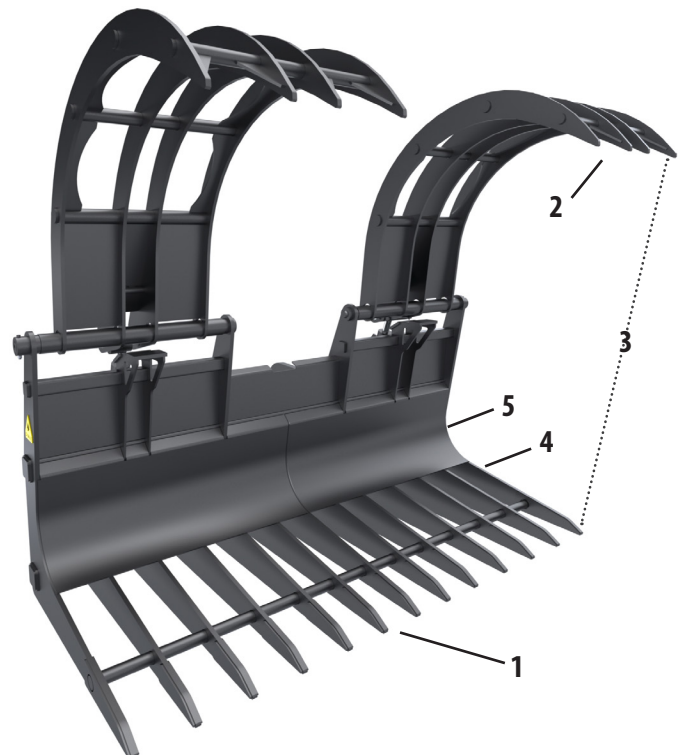

Machine Operating Weight (lbs)	Model No.	Description	Weight (lbs)
20,000-24,000	DX-RK-RFSM-96x10-WL-40 DX-RK-RFSM-102x10-WL-40	Rake-Refuse Small Size-96 inch raking width x 10 steel tines-Wheel Loader-Class 40 Rake-Refuse Small Size-102 inch raking width x 10 steel tines-Wheel Loader-Class 40 STANDARD FEATURES: Clamp opening of 70 inches	2,450
26,000-31,000	DX-RK-RFSM-102x10-WL-50	Rake-Refuse Small Size-102 inch raking width x 10 steel tines-Wheel Loader-Class 50 STANDARD FEATURES: Clamp opening of 70 inches	2,550
Models listed below are LARGER MACHINES suited for machines over 26,000 lbs in operating weight.			
26,000-31,000	DX-RK-RFDG-D105x8-WL-50	Rake-Refuse Double Grapple-105 inch raking width x 8 steel tines with dozer push plate-Wheel Loader-Class 50 STANDARD FEATURES: Clamp opening of 115 inches x 48.5 inch tine length	5,400
32,000-38,000	DX-RK-RFDG-D112x11-WL-60	Rake-Refuse Double Grapple-112 inch raking width x 11 steel tines with dozer push plate-Wheel Loader-Class 60	5,600
	DX-RK-RFDG-D125x12-WL-60	Rake-Refuse Double Grapple-125 inch raking width x 12 steel tines with dozer push plate-Wheel Loader-Class 60 STANDARD FEATURES: Clamp opening of 115 inches x 48.5 inch tine length	6,000
40,000-47,500	DX-RK-RFDG-D125x12-WL-70	Rake-Refuse Double Grapple-125 inch raking width x 12 steel tines with dozer push plate-Wheel Loader-Class 70	6,000
	DX-RK-RFDG-D135x13-WL-70	Rake-Refuse Double Grapple-135 inch raking width x 13 steel tines with dozer push plate-Wheel Loader-Class 70 STANDARD FEATURES: Clamp opening of 115 inches x 48.5 inch tine length	6,400
48,000-56,000	DX-RK-RFDG-D135x13-WL-80	Rake-Refuse Double Grapple-135 inch raking width x 13 steel tines with dozer push plate-Wheel Loader-Class 80	6,400
	DX-RK-RFDG-D145x14-WL-80	Rake-Refuse Double Grapple-145 inch raking width x 14 steel tines with dozer push plate-Wheel Loader-Class 80 STANDARD FEATURES: clamp opening of 115 inches x 48.5 inch tine length	7,000
Models below feature Full Width Grapples			
40,000-47,500	DX-RK-RFFG-D135x13-WL-70	Rake-Refuse Full Width Grapple-135 inch raking width x 13 steel tines with dozer push plate-Wheel Loader-Class 70 STANDARD FEATURES: Clamp opening of 115 inches x 48.5 inch tine length	6,800
48,000-56,000	DX-RK-RFFG-D135x13-WL-80	Rake-Refuse Full Width Grapple-135 inch raking width x 13 steel tines with dozer push plate-Wheel Loader-Class 80	6,800
	DX-RK-RFFG-D145x14-WL-80	Rake-Refuse Full Width Grapple-145 inch raking width x 14 steel tines with dozer push plate-Wheel Loader-Class 80 STANDARD FEATURES: Clamp opening of 115 inches x 48.5 inch tine length	7,500

Design and specifications are subject to change without notice. For custom applications or designs contact Dymax sales 1-800-530-5407

DX-RK-RFSM-96 or 102-WL-40/50

A strong durable rake with smaller capacity suited for those who want great performance but don't need as much capacity. For machines 20,000-31,000 lbs in operating weight.

- 1.5" tine thickness
- Dual grapples
- 70" clamp opening

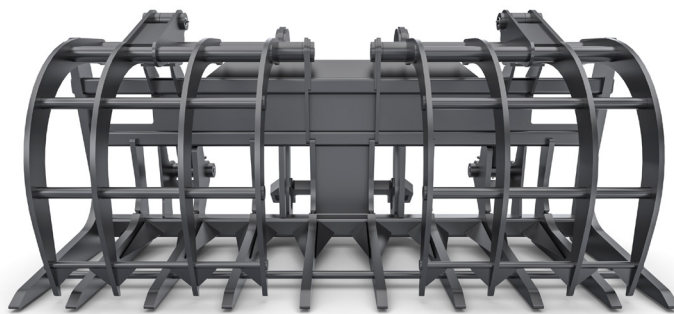

DYMAXINC | Toll Free: 800.530.5407 (USA/CAN)
402 Miller Drive | Office: +1.785.456.2081
Wamego, KS 66547 USA | Fax: +1.785.456.8328

www.DYMAXINC.com
sales@DYMAXINC.com