

OVERVIEW

FOR COMPACT EXCAVATORS (5T-6T)

This 360° rotation grapple features a wide opening that allows for the efficient sorting and loading of materials such as brush, debris and smaller logs. With a lightweight yet sturdy build, it's suitable for landscaping, utility work and construction tasks, where precise handling and fast cycle times are essential.

STANDARD FEATURES

- Twin motor rotation drive with external pinion (DY73499 motors / DY142084 bearing)
- 5.7 inch minimum diameter closing capacity
- 56 inch wide opening between grapple tips
- 2 over 3 intersecting steel tine grapples
- T1 steel laminated tips
- Two 2.5 x 8.0 hydraulic cylinders (DY158390)
- Overall height open: 44.3 inches

OPTIONS

- 12V electro hydraulic valve kit for powering the rotation circuit. Includes valve mounted on the attachment and wiring kit with switch and fuse.

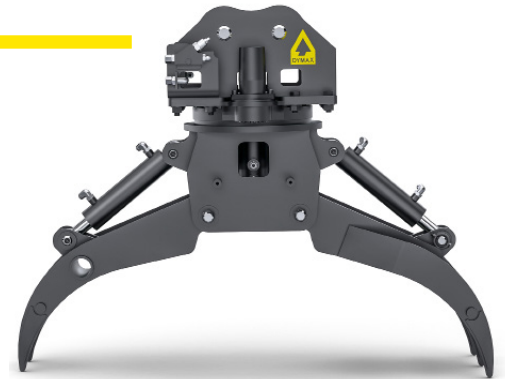

Model Code	Description	Weight
DX-GL-MAT-360-HX-5T	Grapple-Multi-Application Tine-360 degrees rotation-Hydraulic Excavator-5 ton	720 lbs
DX-GL-MAT-360-HX-6T	Grapple-Multi-Application Tine-360 degrees rotation-Hydraulic Excavator-6 ton	720 lbs
Hydraulic Requirements: Your machine requires (2x) hydraulic circuit for operating this attachment. CIRCUIT 1: Grapple Open and Close. GPM Flow Rate: 10-20 GPM. PSI Pressure: 3,000 max psi. CIRCUIT 2: Rotator. GPM Flow Rate: 5-12 GPM. PSI Pressure: 3,000 max psi. NOT SUPPLIED: Jumper hose assembly to and from machine lines.		
Design and specifications are subject to change without notice. Please contact Dymax sales for custom solutions: 1-800-530-5407.		



DYMAX INC | Toll Free: 800.530.5407 (USA/CAN)
 402 Miller Drive | Office: +1.785.456.2081
 Wamego, KS 66547 USA | Fax: +1.785.456.8328

www.DYMAXINC.com
sales@DYMAXINC.com