

OVERVIEW

The **Dymax Bale Grapple Bucket** is a heavy-duty attachment that is specially designed for handling bales of trash at balefill locations, refuse transfer stations and landfills. Operators can efficiently stack, carry and unload up to two bales at a time, making it ideal for loading trucks or placing bales directly into the landfill.

In addition to its specialized bale-handling capabilities, the Bale Grapple Bucket functions as a conventional grapple for handling loose trash and various materials. It's the go-to solution for waste management professionals who need a strong, dependable, multi-functional tool.

KEY FEATURES

- Independent grapple design with bolt-on bale hooks for handling and stacking trash bales efficiently.
- Replaceable bolt-on cutting edge and rear wear pads for extended durability.
- Open side plate design with heavy-duty 1.50 inch T1 corners for reinforced strength.
- Bottom high-tensile steel wear plates and center push screen for improved performance in waste handling applications.
- Hydraulic cushion valve package with relief for smooth and controlled operation.
- Available in 2.00 yd³, 2.50 yd³, and 3.00 yd³ capacities, with widths ranging from 94 to 105 inches.

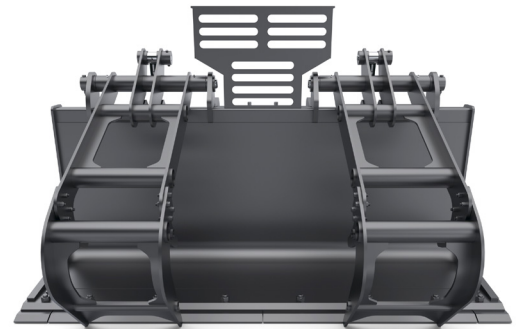
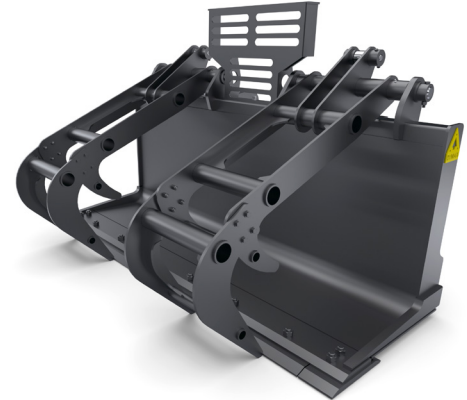

Model Code	Description	Weight
DX-BK-GLBF-2.00cyd-WL-30	Bucket-Grapple Balefill Transfer Station-2.00 cyd capacity-Wheel Loader-Class 30	2560 lbs
DX-BK-GLBF-2.50cyd-WL-40	Bucket-Grapple Balefill Transfer Station-2.50 cyd capacity-Wheel Loader-Class 40	3150 lbs
DX-BK-GLBF-3.00cyd-WL-50	Bucket-Grapple Balefill Transfer Station-3.00 cyd capacity-Wheel Loader-Class 50	3450 lbs

Hydraulic Requirements

Your machine will require 3rd function auxiliary lines.

CIRCUIT 1: Clamp Operation. Type: Two way. Flow/Pressure: GPM (min/max) 15-25, PSI (max) 3,000

NOT SUPPLIED: Does not include jumper hoses to machine lines or quick disconnects.

Design and specifications are subject to change without notice. Please contact Dymax sales for custom solutions: 1-800-530-5407.



DYMAX INC | Toll Free: 800.530.5407 (USA/CAN)
 402 Miller Drive | Office: +1.785.456.2081
 Wamego, KS 66547 USA | Fax: +1.785.456.8328

www.DYMAXINC.com
sales@DYMAXINC.com