

FOLDING V-TYPE SNOW PLOWS**HEAVY DUTY MUNICIPAL & HIGHWAY SNOW REMOVAL ATTACHMENT.**

Angle. V. Scoop. Clear It All.

The Dymax Folding V-Type Snow Plow is a heavy-duty, loader-mounted snow plow designed for municipal streets, state highways, county roads, industrial yards, and large commercial snow removal operations.

This hydraulic V-plow combines:

- Conventional right / left angling
- True reverse V-position for breaking through deep snow
- Scoop forward V-position for snow containment and stacking (*as shown below*)

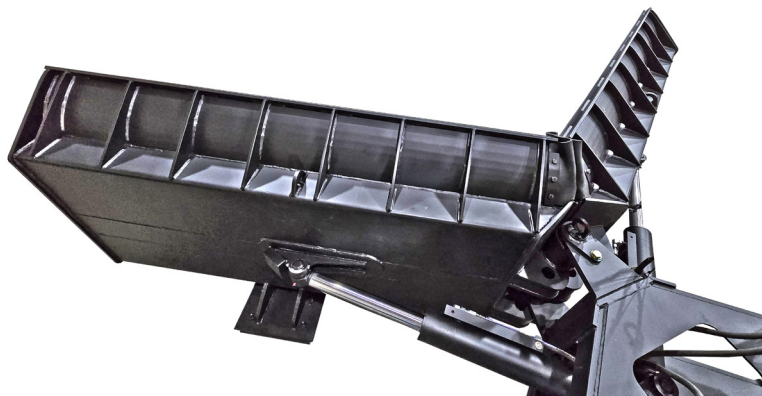
**APPLICATIONS**

- **Snow Removal**

KEY BENEFITS

- **Multi-Position Versatility** – Operates in straight, angle, forward V, or scoop position, giving operators total control in changing snow conditions with one attachment.
- **Break-Through & Contain Performance** – Forward V splits deep drifts fast, while scoop position carries and contains snow for cleaner intersections and parking areas.
- **Hydraulic System Protection Built In** – Twin accumulators on both sides of the diverter valve absorb shock loads, protecting cylinders and loader hydraulics from pressure spikes.
- **Heavy-Duty 4" Bore Cylinders** – Oversized angling cylinders deliver the strength and durability required for municipal routes, highways, and severe winter regions.
- **Built for Harsh Winter Operations** – Available with fixed cutting edge or optional trip edge system, designed to handle hidden obstacles, packed snow, and demanding snow removal fleets.

FEATURES AND SPECIFICATIONS

Model #	Description	Weight
Wheel Loader (Non-Trip) Models		
DX-BL-HAVP-12ftx48in-WL-60	<i>Blade-Hydraulic Angling Vee Type-12 feet wide x 48 inches tall-Wheel Loader-Class 60</i>	3,550
DX-BL-HAVP-14ftx48in-WL-70	<i>Blade-Hydraulic Angling Vee Type-14 feet wide x 48 inches tall-Wheel Loader-Class 70</i>	4,000
Standard Features: Forward and reverse V coverage - shim adjustable rectangular wear shoes - bolt-on replaceable cutting edge 6" center, heat treated - 4.00x20.00 hydraulic cylinders - dual accumulators for shock loading - electro-valve for 4th control function provided with switch and wire kit		
Wheel Loader (TRIP EDGE) Models		
DX-BL-HAVPT-12ftx48in-WL-60	<i>Blade-Hydraulic Angling Vee Trip Edge-12 feet wide x 48 inches tall-Wheel Loader-Class 60</i>	3,750
DX-BL-HAVPT-14ftx48in-WL-70	<i>Blade-Hydraulic Angling Vee Trip Edge-14 feet wide x 48 inches tall-Wheel Loader-Class 70</i>	4,250
Standard Features: Forward and reverse V coverage - shim adjustable rectangular wear shoes - bolt-on replaceable edge with spring loaded trip edge mechanism- 4.00x20.00 hydraulic cylinders - dual accumulators for shock loading - electro-valve for 4th control function provided with switch and wire kit		
Dimensions		
12ft models	Reverse V = 127.00, Forward V = 116.00, Angling L/R = 119.00	
14ft models	Reverse V = 151.00, Forward V = 140.00, Angling L/R = 143.00	

Specifications are subject to change without notice.

Non-Trip Edge

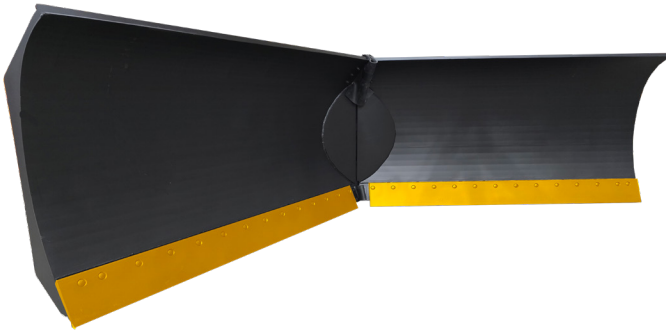

Trip Edge Model

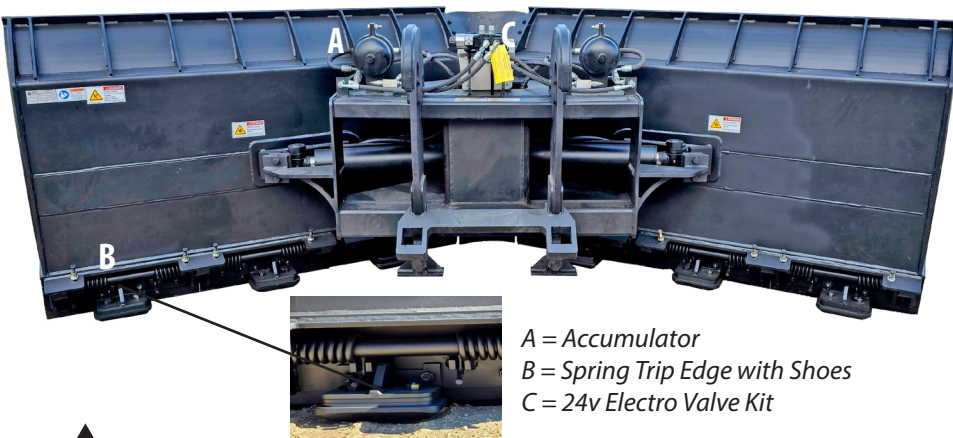

A = Accumulator
 B = Spring Trip Edge with Shoes
 C = 24v Electro Valve Kit

Multi-positioning

Reverse V

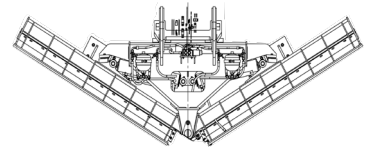

Forward V

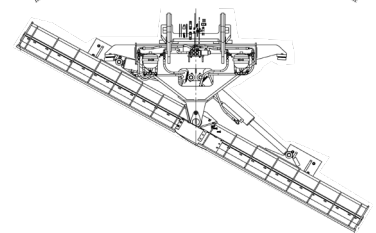
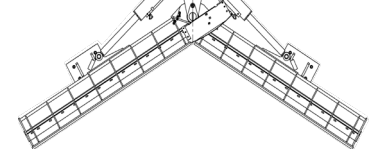
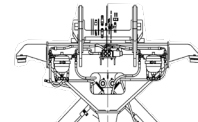

Traditional angling



DYMAXINC | Toll Free: 800.530.5407 (USA/CAN)
 402 Miller Drive | Office: +1.785.456.2081
 Wamego, KS 66547 USA | Fax: +1.785.456.8328

www.DYMAXINC.com
sales@DYMAXINC.com